

Data Sheet for Joysticks

Finger Joystick

Series TRY100



- Good cost/performance ratio
- Shallow installation depth < 26 mm
- Service-friendly due to connectors
- Optional with redundant Hall sensors
- Available interfaces include CANopen, CAN J1939 and USB
- Ideally suited for applications in CCTV, robotics, medical technology and audio/video productions

The TRY100 is the all-rounder in the field of finger joysticks because of the extensive selection of handles, limiters and output options. It offers conventional handle designs as well as modern look & feel variants, in addition analogue outputs and digital interfaces. Thus the joysticks can be optimized for almost all possible applications.

Technical Data

Sensor technology	Hall effect
Supply Voltage	Analogue versions: 5.0 ± 0.5 VDC, transient free Versions with voltage regulator: 8 to 35 VDC (unipolar) / 11 to 35 VDC (bipolar) USB versions: 5.00 VDC (via bus) CAN versions: 7 to 35 VDC
Voltage in Center Position*	2.5 V
Return to Center Accuracy*	±200 mV (valid for output voltage span of 0 to 5 V without load)
Output Linearity*	±200 mV
Output Impedance*	2 Ohm
Load Resistance*	Min. 1 kOhm, recommended > 100 kOhm
Expected Mechanical Life**	5 million cycles**
Output Voltages*	0 to 5 V / 0.5 to 4.5 V / 0.25 to 4.75 V / for others see description on page 2
Supply Current	typ. 40 mA (1 to 2 axes) / max. 50 mA (3 axes)
Angle of Movement X-, Y-Axis / Z-Axis	36° (±18° from center) / 60° (±30° from center)
Operating Force X-Y-Axis	Handles 4, 6, 9, A, 7, 1, 3, 5: typ. 2.8 N / break out force 1.3 N / max. applied: 200 N Handles B, C, D, E: typ. 5 N / break out force 4 N / max. applied: 200 N
Operating Torque Z-Axis	0.12 Nm / break out torque 0.09 Nm / max. applied: 2.5 Nm
Max. vertical Load to Mechanism	200 N (depends on handle)
Operating / Storage Temperature	-40 °C to +85 °C / -40 °C to +85 °C
Above Panel Sealing	Up to IP67 (depending on handle type)
Panel Thickness	1.17 to 3.17 mm (max. 1.6 mm for rear mount option)
EMC Immunity Level (V/M)	EN61000-4-3
EMC Emissions Level	EN61000-6-3:2001
ESD	EN61000-4-2

*Valid only for analogue voltage output. Only valid for the standard variants with analogue output. The output voltage is ratiometric to the input voltage. We therefore recommend using low-noise, stabilized voltage sources.

**Valid only for versions without z-axis and without pushbuttons

Material Information

Shaft Material	Stainless steel
Rubber Boot Material:	Silicone
Handle Materials	Glass filled nylon (depends on handle variant)
Housing Material	Glass filled nylon

Data Sheet for Joysticks

Finger Joystick

Series TRY100

Please contact us for information regarding stock articles, delivery times and minimum order quantities.

Order Description / Options

Description	Selection: standard=black/bold , possible <i>options=grey/italics</i>									
Series	TRY100									
Axes:										
2 Axes, with pushbutton	3									
3 Axes	4									
3 Axes, with pushbutton(s)	5									
2 Axes	2									
1 Axis	1									
1 Axis with pushbutton	6									
Sealing:										
Rubber boot		5								
Return Mechanism:										
Spring return			1							
Handles:										
Handle 4, for 1-2 axes, 1 pushbutton, IP55						4				
Handle 6, for 3 axes, low profile, w/o pushbutton, IP55						6				
Handle 9, for 3 axes, 1 pushbutton, IP55						9				
Handle A, for 3 axes, 2 pushbuttons, IP55						A				
Handle E, for 3 axes, 2 pushbuttons, IP67						E				
Handle 7, for 3 axes, w/o pushbutton, IP55						7				
Handle 1, tapered (not compatible to mounting 2), IP67						1				
Handle 3, ball tip, IP67						3				
Handle 5, for 1-2 axes, 1 pushbutton, IP67						5				
Handle B, for 3 axes, w/o pushbutton, IP67						B				
Handle C, for 3 axes, 1 pushbutton, IP67						C				
Handle D, for 3 axes, 2 pushbuttons, IP67						D				
Limiters:										
Square						1				
Round						3				
Plus "+“ X/Y						9				
1 axis X						7				
1 axis Y						8				
Square "guided feel"						4				
Round "guided feel"						5				
Output Signal:										
0 to 5.0 V (redundant signals parallel / inverse ⁽¹⁾)							1	(1P / 1X)		
0.5 to 4.5 V (redundant signals parallel / inverse ⁽²⁾)							2	(2P / 2X)		
0.25 to 4.75 V (redundant signals parallel / inverse ⁽³⁾)							3	(3P / 3X)		
USB HID compliant game controller ⁽⁴⁾							5			
USB HID compliant mouse emulation ⁽⁴⁾							6			
CAN-bus J1939							7			
CANopen with baud rate 250 kbit/s							8B			
CANopen LSS							9			
Voltage regulator (see below)							0			
Mounting / Housing										
Drop-In									1	
Rear mount									2	
Desktop housing w/o pushbuttons ⁽⁴⁾									M0	
Desktop housing w/ 2 small pushbuttons ⁽⁴⁾									M2	
Desktop housing w/ 2 long pushbuttons ⁽⁴⁾									M2L	
Desktop housing w/ 3 small pushbuttons ⁽⁴⁾									M3S	
Desktop housing w/ 4 small pushbuttons ⁽⁴⁾									M4	
Desktop housing w/ 4 small pushbuttons ⁽⁴⁾									M4D	
Desktop housing w/ 5 small pushbuttons ⁽⁴⁾									M5	
Voltage Regulator ⁽⁵⁾										
Supply +12 to +30 VDC, output 0 to +5 VDC										V1205
Supply +12 to +30 VDC, output ±10 VDC										V1210B

⁽¹⁾ Output signals parallel: 0 to 5 V / 0 to 5 V; output signals inverse: 0 to 5 V / 5 to 0 V

⁽²⁾ Output signals parallel: 0.5 to 4.5 V / 0.5 to 4.5 V; output signals inverse: 0.5 to 4.5 V / 4.5 to 0.5 V

⁽³⁾ Output signals parallel: 0.25 to 4.75 V / 0.25 to 4.75 V; output signals inverse: 0.25 to 4.75 V / 4.75 to 0.25 V

⁽⁴⁾ Versions with digital interface (USB, CAN) in desktop housings only available as custom construction. Please contact us.

⁽⁵⁾ The switching power supply for the electronics of this device requires an initial current of at least 100 mA.

The use of power supply units with current limiters operating below this threshold can damage the circuitry of the joystick!

⁽⁶⁾ Mouse-Emulation not officially supported for Linux. See details on page 4.

Data Sheet for Joysticks

Finger Joystick

Series TRY100

For higher quantities or on-going demand, additional options are available

- Redundant output signals (inverted or parallel)
- Increased return-to-center spring tension
- Voltage regulator
- Customer-specific cables

Limiters

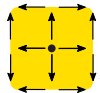

Square - Option "1"



1-axis "X" - Option „7“

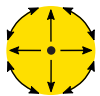

Round - Option "3"



1-axis "Y" - Option „8“



Square "guided feel" ⁽¹⁾ - Option "4"



X/Y Plus "+" - Option „9“



Round "guided feel" ⁽¹⁾ - Option "5"



X/Y Cross "x" - Option „D“

⁽¹⁾ "guided feel" still allows the joystick handle to be deflected omni-directionally, but as the operation force needed for the main axes is slightly below the force needed for diagonal deflection the resulting impression is that of a „guided movement“.

Connection description for analogue outputs (output options 1-3)

The analogue outputs are supplied with your Hirose connector type DF11-12DP-2DS9 (24) (pin connector, see the first illustration on the right). We optionally offer the appropriate connection cable (length approx. 25 cm) with Hirose DF11-12DS-2C connector (item no. 129802).

We are happy to supply other lengths and configurations on request. For the connection configuration of joysticks with digital outputs (CAN-bus, USB interface) see the respective sections below.



Pin assignment for analogue outputs (output options 1-3)

Pin	Function	Colour	Pin	Function	Colour
1	Ground	black	7	Z axis dual output	grey (old: green/black)
2	Vcc	red	8	Z axis	green
3	X axis dual output	pink (old: blue/white)	9	Pushbutton 1	orange
4	X axis	blue	10	Pushbuttons 1/2 Common	white
5	Y axis dual output	brown (old: yellow/black)	11	Pushbutton 2	violet
6	Y axis	yellow	12	Not used	Not used

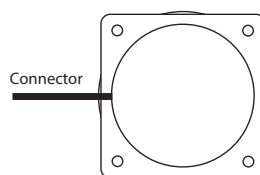
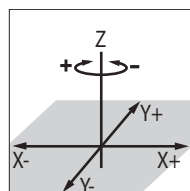

Data Sheet for Joysticks

Finger Joystick

Series TRY100

USB specifications (output options 5-6)

Supply voltage	5 V
Max. current consumption:	70 mA
USB version:	2.0
Operating systems:	Windows 7, Windows 8.1, Windows 10
Cable outlet	USB mini B connector (at housing)
Cable (included)	USB cable (length approx. 198 cm, min. bending radius 34 mm) with USB A plug to USB mini B plug.

The USB controller is integrated in the joystick housing. The joystick is powered via the interface cable. Most Windows and Linux versions recognize the device without additional drivers.

There are two different configurations of the joystick available according to the data sheet:

USB HID compliant game controller (option 5)

The device identifies itself on the USB bus as a USB 2.0 HID-compliant game controller, i.e. as a joystick.

USB HID-compliant mouse emulation (USB joystick as a mouse replacement, option 6)

Optionally, the joystick can also be operated as a mouse replacement. In this case, the device identifies itself on the USB bus as a USB 2.0 HID-compliant mouse. The X and Y axes are converted in the movement of the mouse pointer on the screen. The third axis acts as an additional input element similar to a mouse wheel and can be assigned various functions by the user. Button 1 is a left mouse button, button 2 is a right mouse button. Linux kernels are not officially supported, but might work.

Technical data voltage regulator (options V1205, V1210B)

As a special option, the joystick TRY100 can be equipped with a voltage regulator, which enables the joystick to be operated with various input voltage signals. There are two variants to choose from: The unipolar variant (V1205 option), the output is 0-5 V (ask us for other outputs). The bipolar variant (option V1210B) generates a bipolar signal of ± 10 V at the axis outputs (middle position at approx. 0 V, output option „0“ only).

Maximum power consumption:	90 mA
Cable assembly:	AWG28 16.5 \pm 1.25 cm PTFE
Supply voltage unipolar variant (V1205):	7-35 V
Supply voltage bipolar variant (V1210B):	11-35 V

Housing dimensions of the voltage regulator versions (options V1205, V1210B)

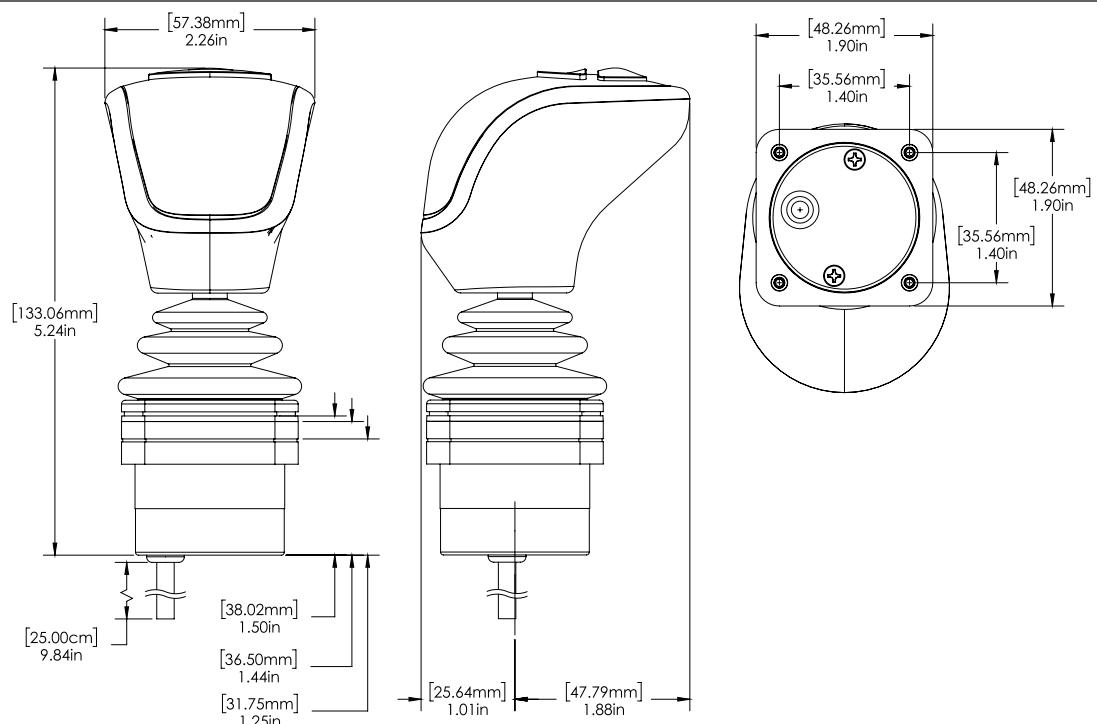

Data Sheet for Joysticks

Finger Joystick

Series TRY100

Cable configuration CAN-bus versions (output options 7-9)

TRY100 series joysticks with CAN-bus output (output options 7-9) are delivered with a JST B6B-PH-S (LF) (SN) connector in combination with a 56 cm cable harness (AWG22, PTFE, JST PHR-6 , stripped ends, tinned). The table on the left shows the assignment / functions of the individual pins on the housing or the different strands.

Pin	Colour	Function
6	red	Supply voltage 7-35 V
5	black	Ground GND
4	orange	ID / Node ID select LSB
3	blue	ID / Node ID Select MSB
2	green	CAN high
1	white	CAN low



Cable harness with connector JST-PHR-6

Housing dimensions of the CAN-bus versions (output options 7-9)

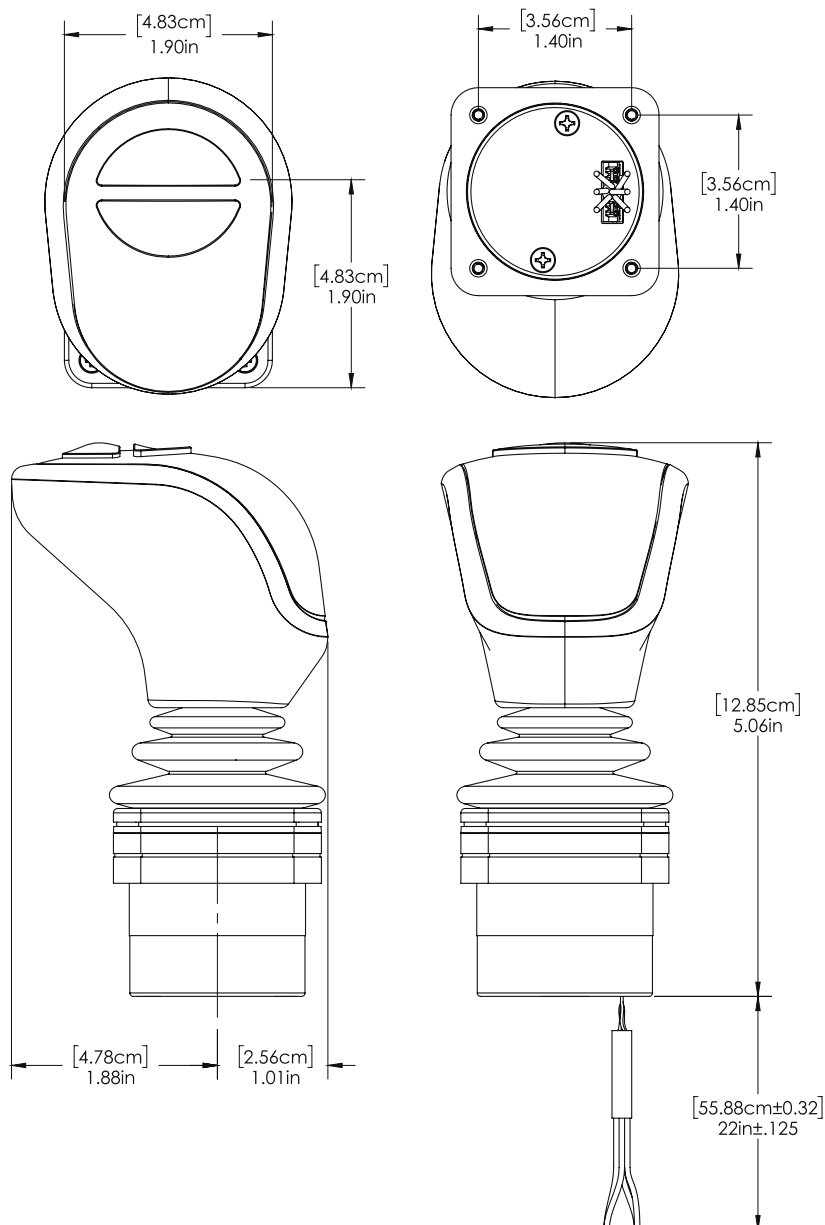

Data Sheet for Joysticks

Finger Joystick

Series TRY100

Technical data CAN J1939 version (output option 7)

The TRY100 series can be configured with a maximum of 3 proportional axes and with a maximum of 2 buttons. The axis information and button data are transmitted via a CAN 2.0B-compatible physical interface. Two additional wires allow the address of the controller to be configured. The controller transmits its information in accordance with the SAE J1939-71 protocol. For the exact structure of the data packages, see the tables on the next page.

Transmission repetition rate	50 ms
Terminal resistor	None
Baud rate	250 kbit/s
CAN ID format	29 bit (CAN 2.0B)
BJMI/EJMI interval time	20 ms

For higher quantities or on-going demand, additional options are available

- Redundant joystick versions with CAN-bus
- Other Baud rates 125 kbit/s, 500 kbit/s, 1 Mbit/s
- Customer-specific CAN addresses and output configuration

Data CAN J1939-71 protocol (output option 7)

- Primary axis and Pushbutton data on Basic Joystick Message 1 (BJM1):
 - Priority: 3
 - PGN: 0xFDD6
 - Source address: 0x16⁽¹⁾
 - Length of data field: 8 bytes

- Redundant axis and Pushbutton data on Extended Joystick Message 1 (EJM1):
 - Priority: 3
 - PGN: 0xFDD7
 - Source address: 0x16⁽¹⁾
 - Length of data field: 8 bytes

⁽¹⁾ Alternative source addresses can be configured by grounding the blue and / or orange wires:

- Source address = 0x16: ORANGE = floating, BLUE = floating (standard)
- Source address = 0x26: ORANGE = floating, BLUE = grounded
- Source address = 0x36: ORANGE = grounded, BLUE = floating
- Source address = 0x46: ORANGE = grounded, BLUE = grounded

BJM1 data field configuration (output option 7)

Start position (BYTE/BIT)	Length (BITS)	Function
1/1	2	Primary data X-axis, status neutral position
1/3	2	Primary data X-axis, status left position (minimum value)
1/5	2	Primary data X-axis, status right position (maximum value)
1/7 to 2/8	10	Primary data X-axis, axis position
3/1	2	Primary data Y-axis, status neutral position
3/3	2	Primary data Y-axis, status backward position (minimum value)
3/5	2	Primary data Y-axis, status forward position (maximum value)
3/7 to 4/8	10	Primary data Y-axis, axis position
6/5	2	Button 2 status
6/7	2	Button 1 status

Data Sheet for Joysticks

Finger Joystick

Series TRY100

EJM1 data field configuration (output option 7)

Start position (BYTE/BIT)	Length (BITS)	Function
1/1*	2	Redundant data X axis, status neutral position *
1/3*	2	Redundant data X axis, status left position (minimum value) *
1/5*	2	Redundant data X axis, status right position (maximum value) *
1/7 bis 2/8*	10	Redundant data X axis, axis position *
3/1*	2	Redundant data Y axis, status neutral position *
3/3*	2	Redundant data Y axis, status reverse position (minimum value) *
3/5*	2	Redundant data Y axis, status forward position (minimum value) *
3/7 bis 4/8*	10	Redundant data Y axis, axis position *
5/1	2	Z axis primary data, neutral position status
5/3	2	Primary data Z axis status deflection counterclockwise
5/5	2	Primary data Z-axis status deflection clockwise
5/7 to 4/8	10	Primary data Z axis, axis position

*Redundant outputs are available as a special version

Technical data CANopen version (output option 8B)

The TRY100 series can be configured with a maximum of 3 proportional axes and 2 buttons. Two additional lines allow the address of the controller to be configured. The following configuration applies to the CANopen® protocol. To use LSS (Layer Setting Service), please select the exit option „9“ according to the order key.

Node ID:	20h
Baud rate:	250 kbit/s
Push button data:	Button status is transmitted in a 1 byte data frame with the identifier 1A0 (180h + node ID)
Axis data:	Axis data are transmitted in a 3 byte data frame with the identifier 2A0 (280h + node ID)
Heartbeat (500 ms):	720h (700h + node ID)
Axis resolution:	8 bit
Network management:	Autostart activated

Alternative node IDs can be configured by grounding the blue and/or orange wires:

- Node ID = 20H ORANGE= floating, BLUE= floating (standard)
- Node ID = 21H: ORANGE= floating, BLUE= grounded
- Node ID = 22H: ORANGE= grounded, BLUE= floating
- Node ID = 23H: ORANGE= grounded, BLUE= grounded

Button data (output option 8B)

Identifier	1A0
Byte 0	Buttons 2:0

Axis data (output option 8B)

Identifier	2A0
Byte 0	A_IN0 [7:0]
Byte 1	A_IN1 [7:0]
Byte 2	A_IN2 [7:0]

Data Sheet for Joysticks

Finger Joystick

Series TRY100

Technical data CANopen LSS (output option 9)

The TRY100 series can be configured with a maximum of 3 proportional axes and 2 buttons. Two additional wires allow the address of the controller to be configured. The CANopen LSS interface option follows the CiA305 and CiA401 standards from CiA (CAN in Automation). Node ID, baud rate and additional configurations can be set and saved in the EEPROM Service Data Object. The default settings are as follows:

Node ID:	20h
Baud rate:	250 kbit/s
Push button data:	Button status is transmitted in a 1 byte data frame with the identifier 1A0 (180h + node ID)
Axis data:	10-bit axis data are transmitted in a 6-byte data field with the identifier 2A0 (280h + node ID)
Heartbeat (500 ms):	720h (700h + node ID)
Axis resolution:	10 bit
Network management:	Autostart activated

Alternative node IDs can be configured by grounding the blue and/or orange wires:

- Node ID = 20H: ORANGE= floating, BLUE= floating (standard)
- Node ID = 21H: ORANGE= floating, BLUE= grounded
- Node ID = 22H: ORANGE= grounded, BLUE= floating
- Node ID = 23H: ORANGE= grounded, BLUE= grounded

Button data (output option 9)

Identifier	1A0
Byte 0	Taster 2:0

Axis data (output option 9)

Identifier	2A0
Byte 0	A_IN0 [7:0]
Byte 1	A_IN1 [9:8]
Byte 2	A_IN2 [7:0]
Byte 3	A_IN1 [9:8]
Byte 4	A_IN2 [7:0]
Byte 5	A_IN2 [9:8]

For higher quantities or on-going demand, additional options are available

- Redundant joystick versions with CAN-bus
- Other Baud rates 125 kbit/s, 500 kbit/s, 1 Mbit/s
- Customer-specific CAN addresses and output configuration

Handle versions

Handle 1



Drop-In mounting only

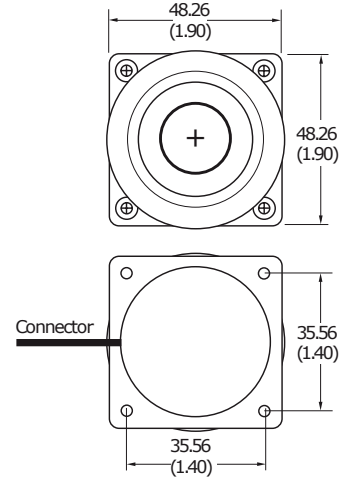
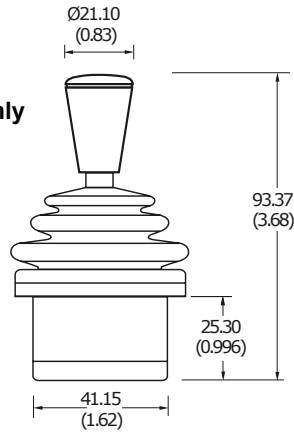

Handle 3

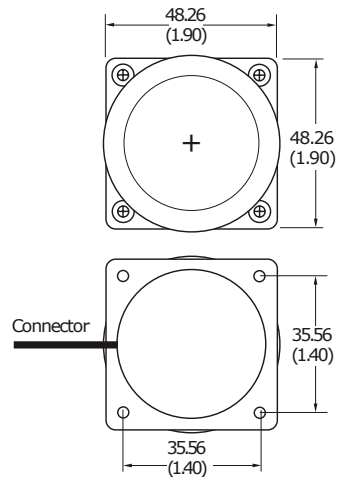
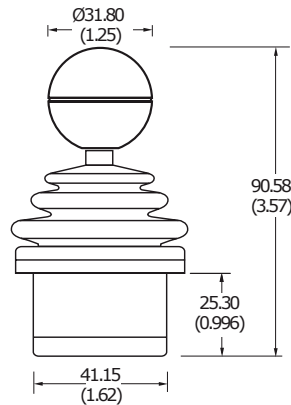

Handle 4

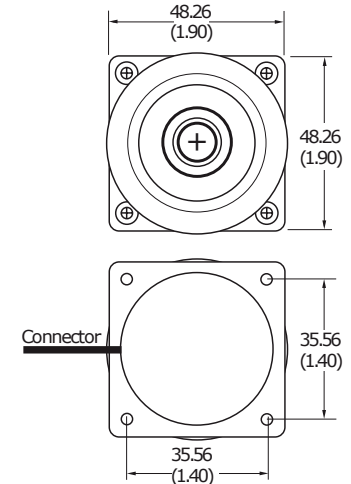
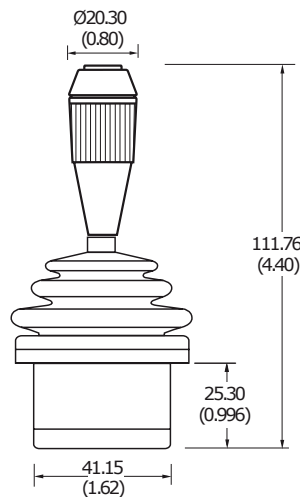

All dimensions in mm (inches)

Handle versions

Handle 5

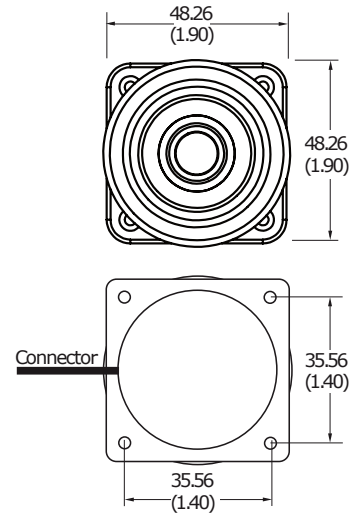
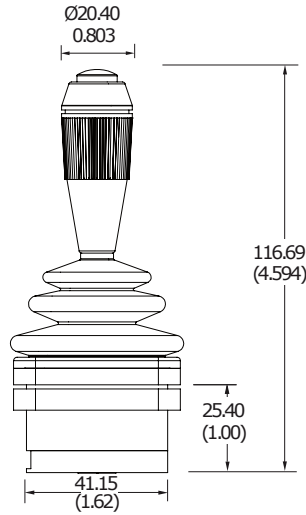

Handle 6

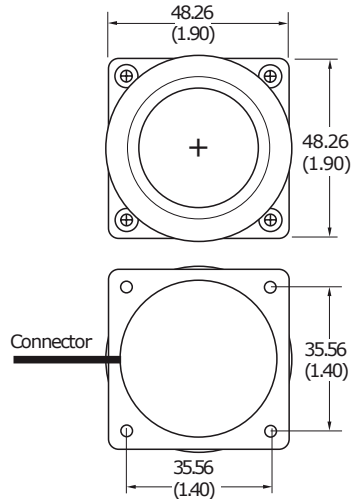
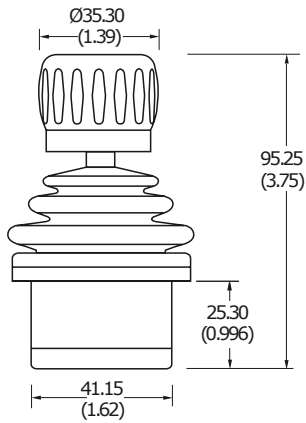

Handle 7

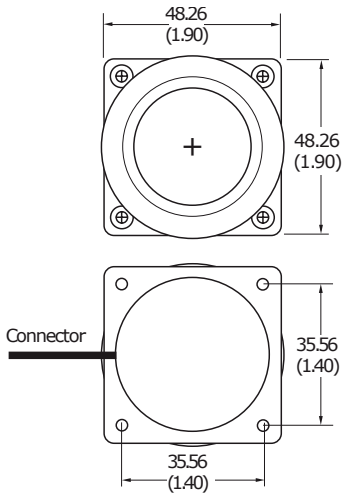
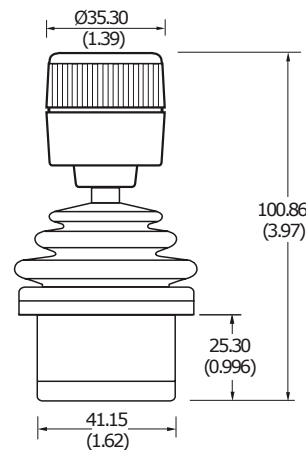

All dimensions in mm (inches)

Handle versions

Handle 9

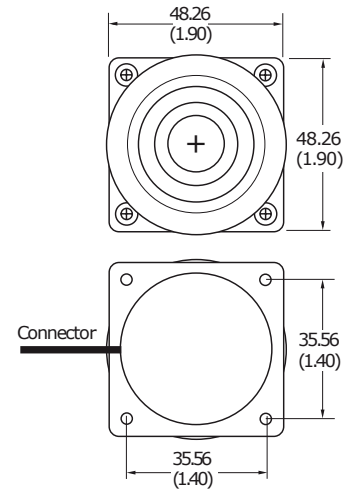
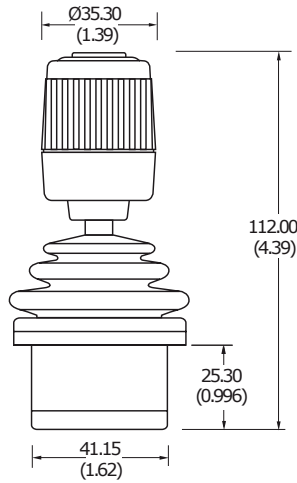

Handle A

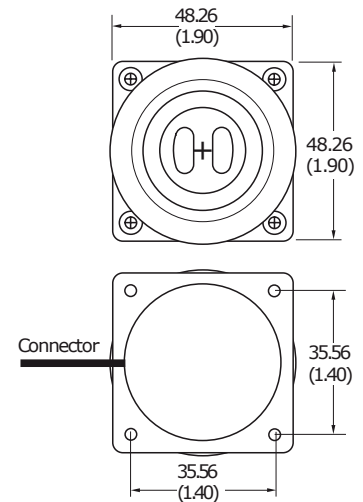
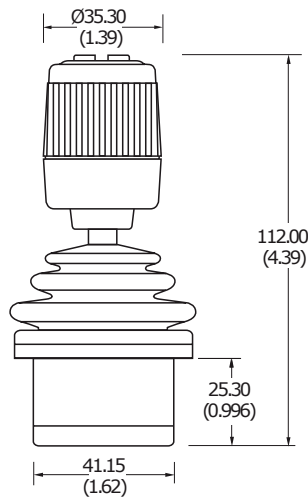

Pushbutton rating: approx. 200.000 operations at no load

Handle B

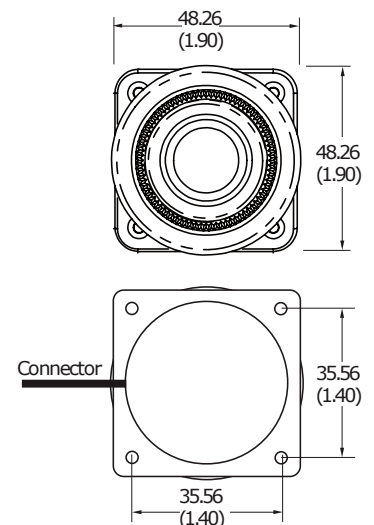
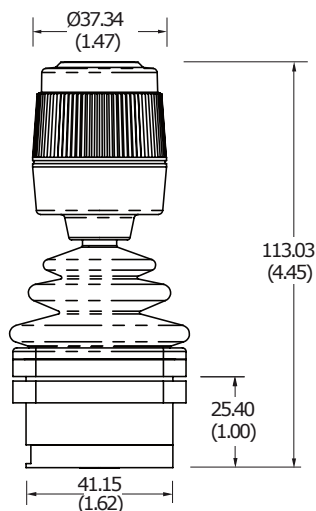

All dimensions in mm (inches)

Handle versions

Handle C

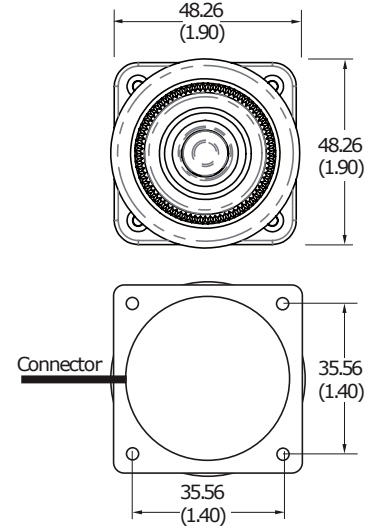
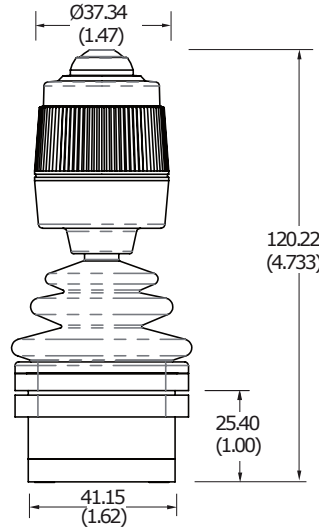

Handle D

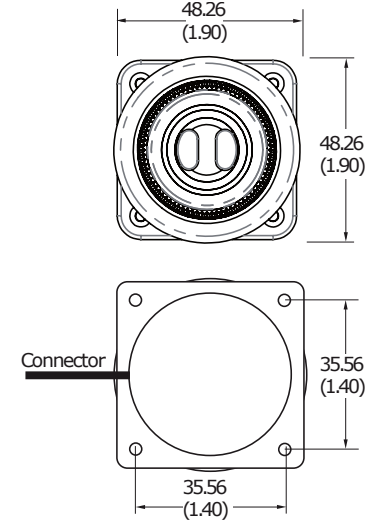
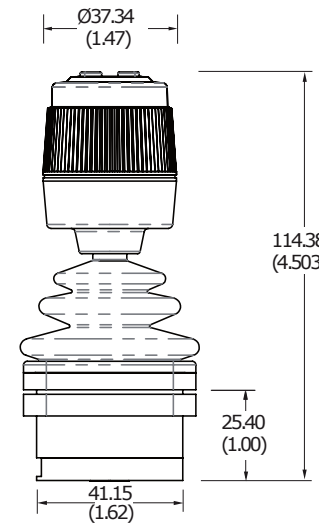

Pushbutton rating: approx. 200.000 operations at no load

Handle E

Drop-In mounting only

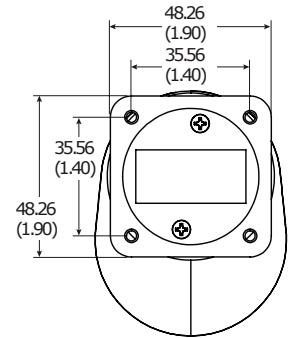
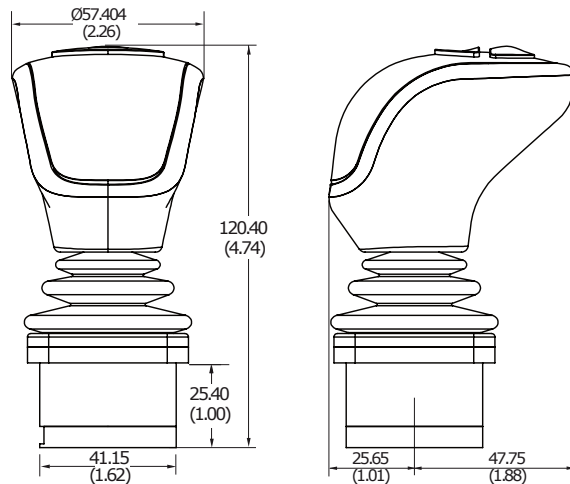

All dimensions in mm (inches)

Mounting Options

Drop-In Option „Mounting 1“

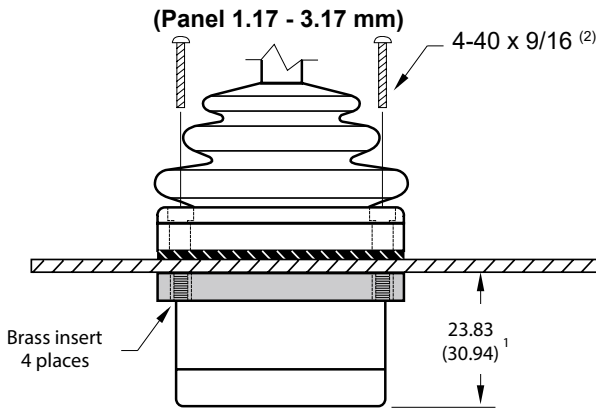

Rear Mount Option „Mounting 2“

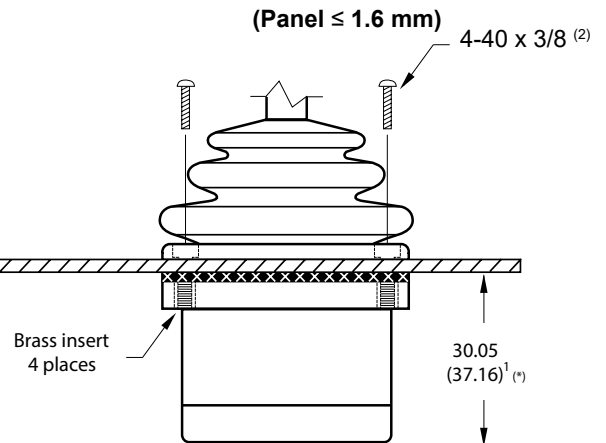

- Panel
- Gasket
- Rear Mount Gasket

(*) at panel thickness 1.6 mm

⁽¹⁾ Below-panel depth is extended by 7.11 mm for CAN and voltage regulator options.

⁽²⁾ 4 pcs. of mounting screws supplied with each joystick.

Clamping ring

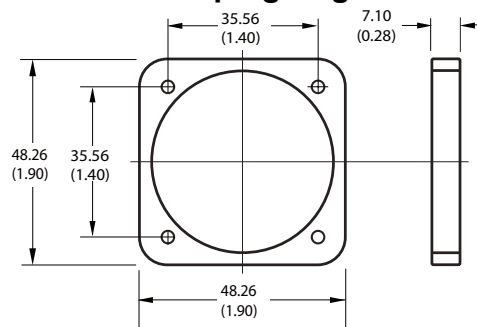

Drop-In Option „Housing 1“

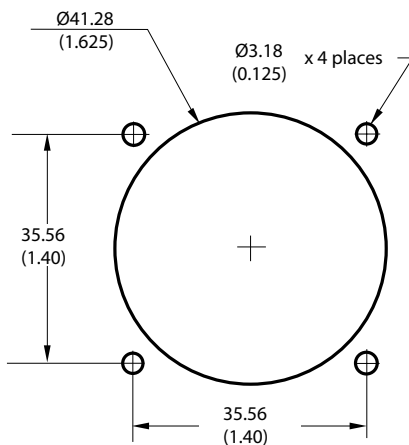

Rear Mount Option „Housing 2“

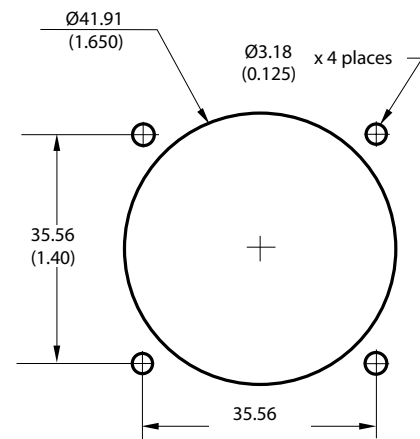

All dimensions in mm (inches)

Data Sheet for Joysticks

Finger Joystick

Series TRY100

Option desktop housing



Colour of the desktop housing is black (handle and pushbuttons black).

USB versions are only available as custom construction.

Please note the those versions are custom-made and are not tested by us towards RFI/EMC. If desktop joysticks are used as standalone parts, for using them in the European Union, they must be CE-certified, therefore the customer must test these versions for CE certification. Please contact us if you need a different configuration than the ones shown for your project.



Standard configurations: Please contact us if you need a different configuration for your project than the ones shown.

Dimensional drawing desktop housing

